

MV Medelpad



General

Built	1985
Length over all	92,50 m
Breadth moulded	13,80 m
max. draught	4,50 m
max. DWCC	2.650,00 mt
Speed	abt. 11,5 knots
GT	2.681,00 London Rules
NT	1.116,00 London Rules

Cargohold

Hatch / Hold	1 / 1
	Hydraulic operated piggy pack system
Bale	5.200 cbm / 182.000 cft

Class

Germanischer Lloyd: 100 A 4 E 3 + MC E 3 AUT strengthened for heavy cargo "G" equipped for carriage of containers
Ice class E 3 - according finish ice class 1 A

Cranes

2 electro hydraulic cranes
SWL 25 to min / max. outreach 2,70 m - 18,00 m

Engine

Consumption	7,0 to / 11,5 knots
Port Consumption	0,8 to gasoil / day
Fuel Specification	IFO 100 cst according ISO 8217
Main Engine	1 x MaK Kiel, "6 M 453 B", 1.470 kW, 535 rpm qualified for heavy fuel oil IF 100
Auxiliary Engine	2 x Zepp. / Catapillar, type: "3406 DI-TAU" each 270 kw - 1.800 rpm, qualified for gasoil

Cargo / Container Capacity

Container intake	166 TEU
Container intake	
14 to homogeneous	147 TEU
Timber intake	LP abt. 4.800 cbm
Pulpwood intake	conifer abt. 2.400 cbm
	birch abt. 2.200 cbm

in hold 20' TEU

1st tier	36
2nd tier	36
3rd tier	36
total in hold	108

on deck

1st tier	48
2nd tier	10
total on deck	58
total hold and deck	166

Container Pointload

on tanktop	60 to	per 20'	TEU stack
on hatchcovers	23 to / 35 to	per 20' / 40'	TEU stack

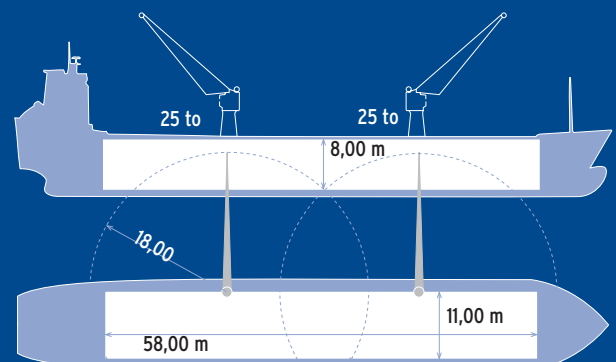

all details about